



Pompe da drenaggio con girante aperta per il pompaggio di liquidi con corpi in sospensione. Caratterizzate da alta prevalenza in rapporto al tipo e alla grandezza della macchina.

Drainage pump with open impeller for pumping liquids with suspended solids. Characterised by head in ratio to the type and size of the machine.

Bombas de drenaje con rodete abierto para bombear líquidos con cuerpos en suspensión. Caracterizadas por una alta prevalencia en relación con el tipo y el tamaño de la máquina.

Pompes de drainage avec turbine ouverte pour le pompage de liquides avec corps en suspension. Caractérisées par une hauteurmanométrique élevée par rapport au type et aux dimensions de la machine.

**CARATTERISTICHE COSTRUTTIVE / CONSTRUCTION FEATURES
CARACTERÍSTICAS CONSTRUCTIVAS / CARACTÉRISTIQUES D'EXÉCUTION**

Corpo pompa Pump body Cuerpo bomba Corps de pompe	ghisa cast iron fundición fonte
Camicia, coperchio motore, base appoggio Shell, motor cover, base support Camisa, tapa motor, base apoyo Chemise, couvercle moteur, support de base	acciaio inox stainless steel acero inoxidable acier inox
Girante Impeller Rodete Turbine	ottone brass latón laiton
Tenuta meccanica Mechanical seal Sello mecánico Garniture mécanique	doppia tenuta con barriera d'olio: carburo di silicio lato pompa, anello di tenuta lato motore double seal with oil barrier; silicon carbide on pump side, sealing ring on motor side doble sello con cámara interpuesta: carburo de silicio lado bomba, retén de estanqueidad lado motor double garniture avec film lubrifiant: carbure de silice côté pompe, joint d'étanchéité côté moteur
Albero motore Motor shaft Eje motor Arbre moteur	acciaio AISI 430 stainless steel AISI 430 acero AISI 430 acier AISI 430
Passaggio corpi solidi Passage of solids Paso de solidos Passage corps solides	Ø max 10 mm
Profondità di immersione Depth of immersion Profundidad inmersión Profondeur immersion	max 5 m
Temperatura del liquido Liquid temperature Temperatura del líquido Température du liquide	0 - 40 °C
Cavo Cable Cable Câble	H07 RNF, 10 m

G	galleggiante float switch flotador flotteur
----------	--

MOTORE / MOTOR / MOTOR / MOTEUR

Motore 2 poli a induzione 2 pole induction motor Motor de 2 polos a inducción Moteur à induction à 2 pôles	3~ 3x380V - 60Hz 1~ 1x220V - 60Hz (con termoprotettore) (with thermal protection) (con protección térmica) (avec protection thermique)
---	--

Classe di isolamento Insulation class Clase de aislamiento Classe d'isolation	F
Grado di protezione Protection degree Grado de protección Protection	IP68

1~ 110V - 60Hz	
TYPE	I (A)
DH 80	8,6
DH 100	12,4

				
TYPE	TRUCK		CONTAINER	
	PALLET (cm)	N° pumps	PALLET (cm)	N° pumps
DH	80X120X125	57	80X120X165	76

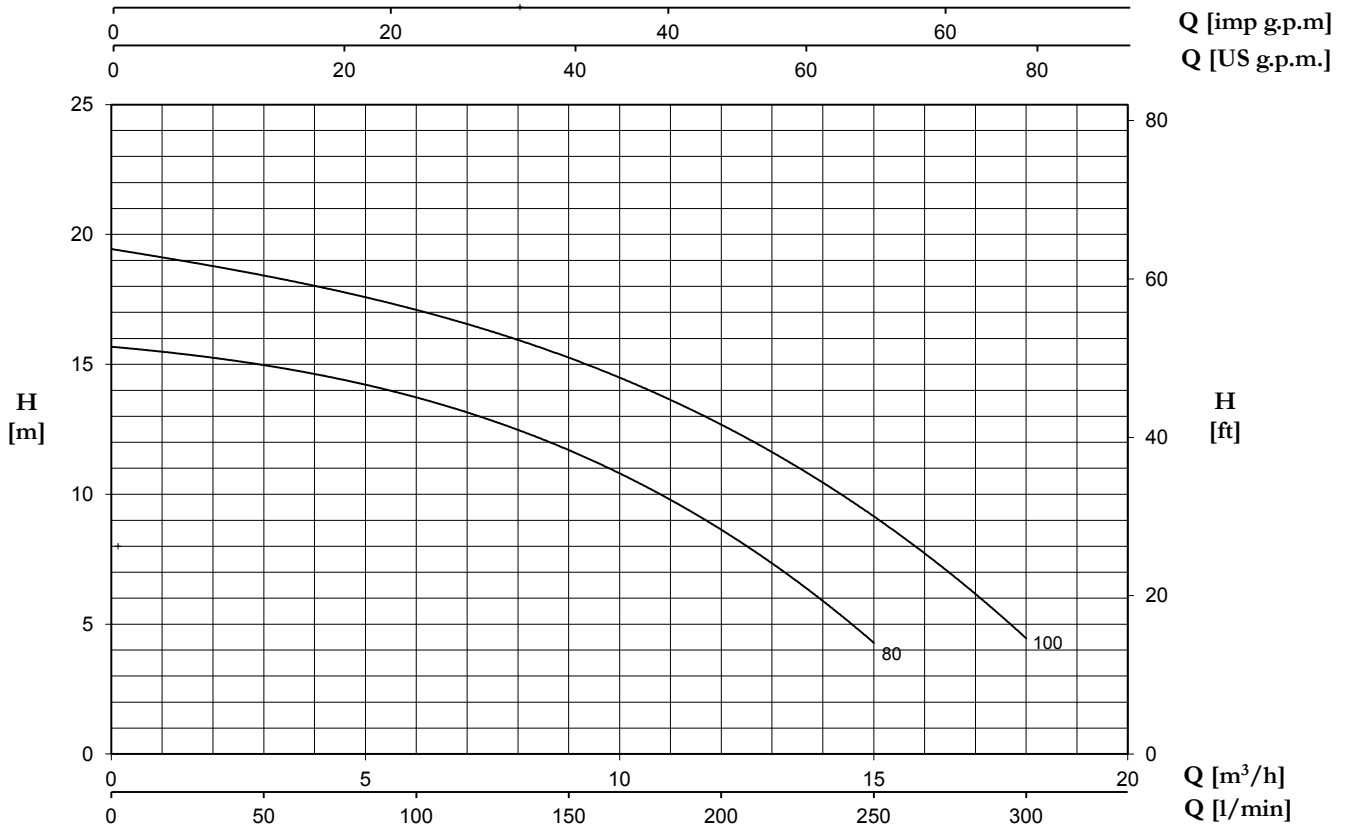

TYPE		W	AMPERE		Q (m³/h - l/min)							
1~	3~		1~	3~	0	3	6	9	12	15	18	
					0	50	100	150	200	250	300	
						H (m)						
DH 80 (G)	DHT 80	980	4,3	2,1	15,7	14,9	13,8	11,7	8,6	4,3	-	
DH 100 (G)	DHT 100	1370	6,2	2,8	19,4	18,5	17,1	15,2	12,6	9,3	4,4	

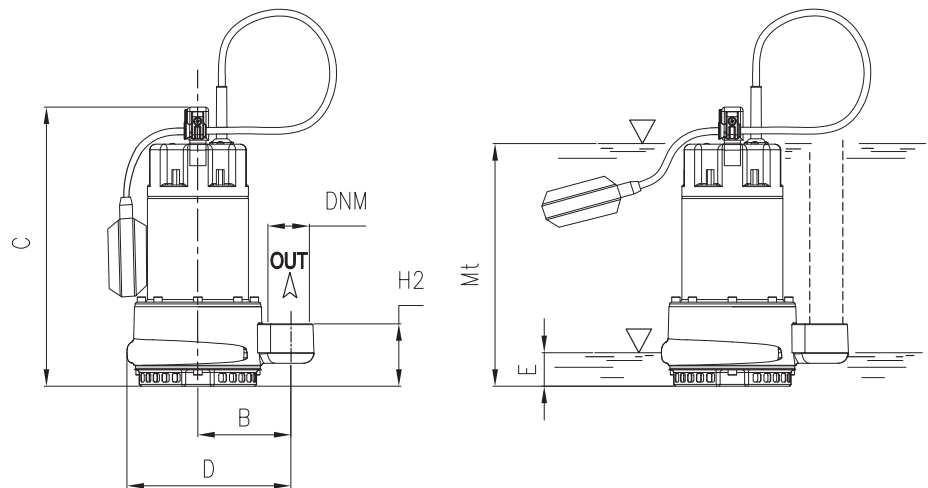

E: massimo livello di svuotamento
 E: maximum emptying level
 E: máximo nivel de vaciado
 E: niveau maximum de vidange

Mt: livello minimo di funzionamento continuo
 Mt: lowest level for continuous duty
 Mt: nivel minimo de funcionamiento continuo
 Mt: niveau minimum de fonctionnement continuu

TYPE	DIMENSIONS (mm)										Kg
	B	C	D	E	H2	Mt	DNM	I	L	M	
DH 80 G	105	330	218.5	45	70	190	1" 1/2G	180	255	380	14,5
DH 100 G	105	330	218.5	45	70	190	1" 1/2G	180	255	380	15,5

