

- A – Packing
- B – Mating Ring
- C – Primary Ring
- D – Bellows Assembly
- E – Steam Guide
- F – Gland
- G – Spiral Wound Gasket
- H – Setting Spacer
- I – Packing Follower
- J – Sleeve

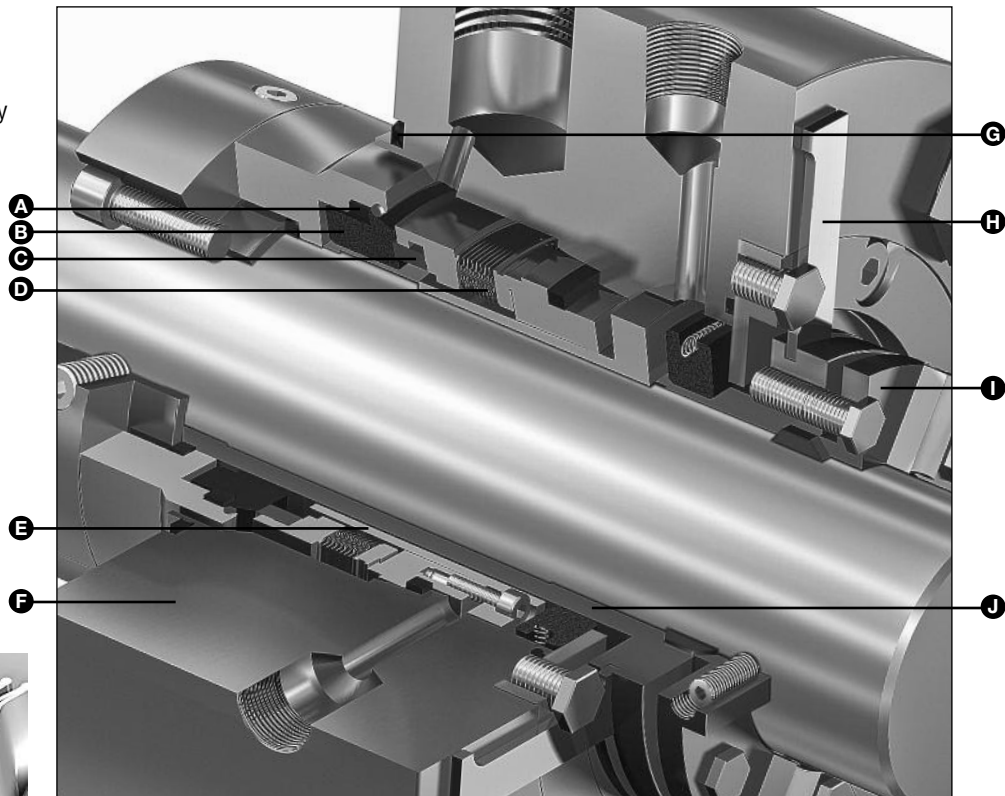

Welded Metal Bellows

Type 1604

Product Description

Type 1604 is a high-temperature API 682, Type C, Arrangement 1 stationary single metal bellows cartridge seal. The Type 1604 is capable of handling high shaft speed applications and high shaft-to-seal chamber misalignment.

Performance Capabilities

- Temperature: -330°F to 800°F/-200°C to 425°C
- Pressure: vacuum to 360 psi(g)/25 bar(g)
- Speed: up to 10,000 fpm/50 m/s
- Shaft size: 1.5" to 4.5"/30mm to 120mm

Design Features

- API 682 Qualification Tested
- Seal Edge-Welded Metal Bellows
- Easy-To-Install Cartridge Design with Registered Fit
- Elastomer-Free Design
- Standard Components
- Steam Guide for Effective Mitigation of Coking Hot Hydrocarbons
- Segmented Spring-Loaded Carbon Throttle Bushing for Effective Containment
- Retained Mating Ring Available for Vacuum Service

Typical Applications

- Hydrocarbons
- Aromatic fractionation products (benzene, toluene, solvents, etc.)
- Crude oil fractionation products (fuel oil, lubricating oil, gasoline, etc.)
- Chemicals, caustics, some acids, aqueous solutions, lubricating liquids

TYPE 1604

API 682 TYPE C ARRANGEMENT 1 METAL BELLOWS SEAL

Type 1604 API Type C Arrangement 1 - Single Cartridge

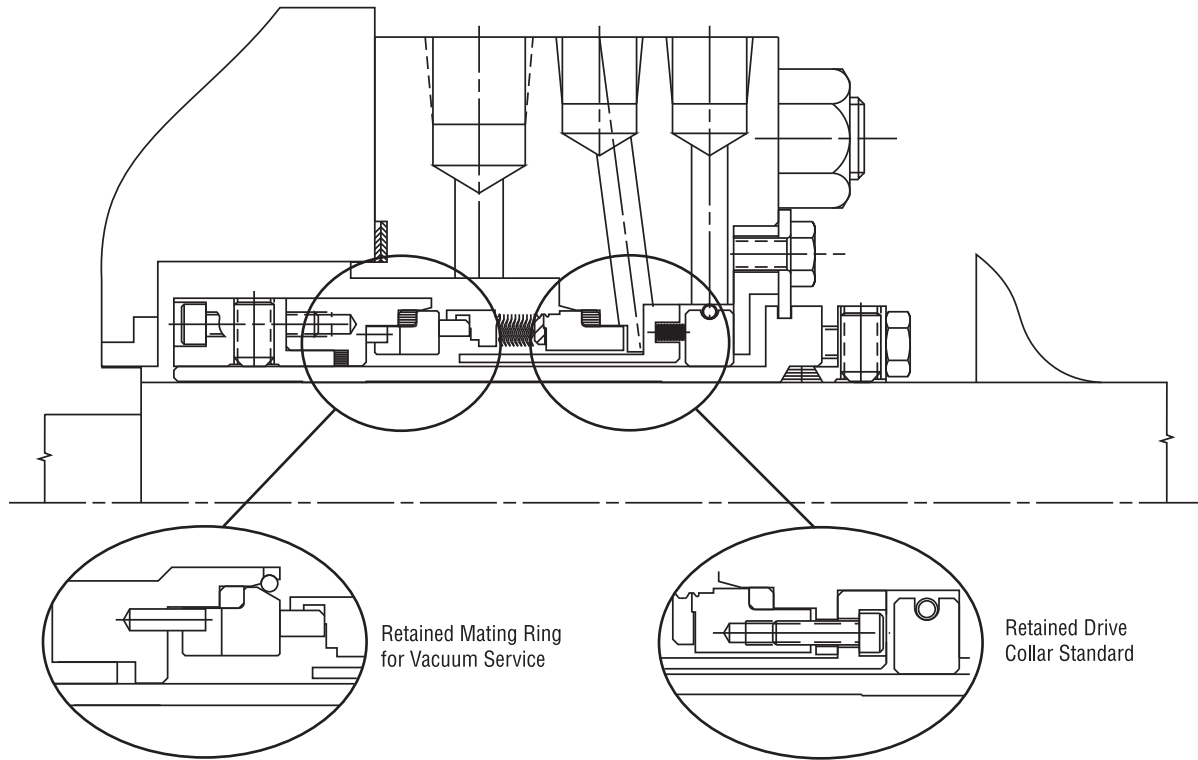

Piping Plan Recommended with the Type 1604

API Plan 11

Recirculation from pump case through orifice to seal.

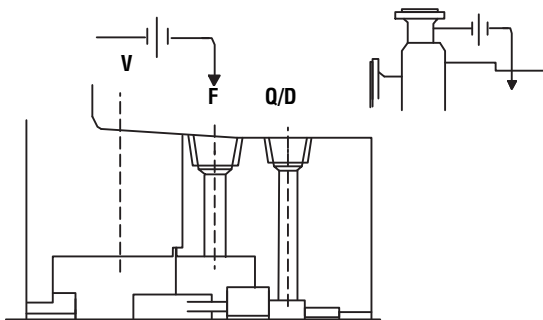

API Plan 62

External fluid quench (steam, gas, water, etc.) typically used with throttle bushing.

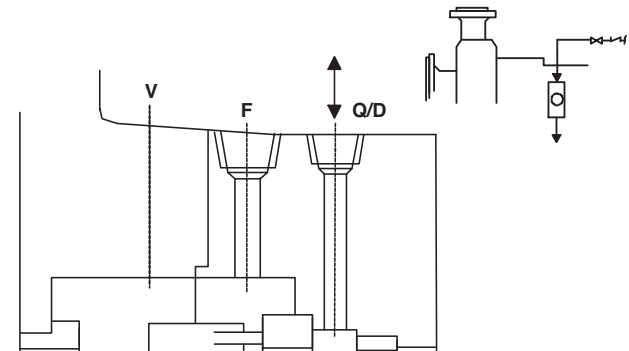

Basic Pressure Rating

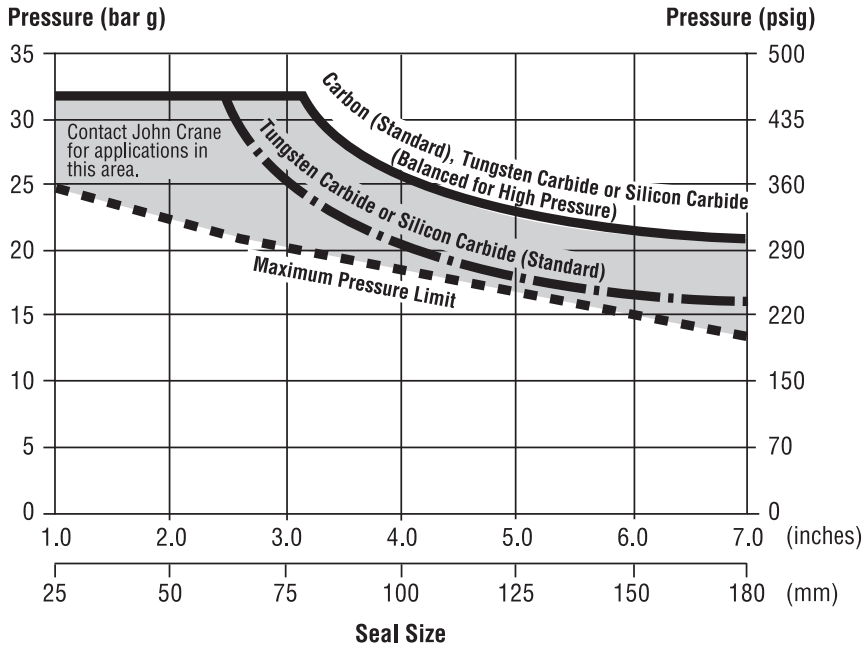

The basic pressure rating is for a standard seal as shown in the typical arrangement, when installed according to the criteria given in this data sheet and generally accepted industrial practices.

The basic pressure rating assumes stable operation at 3600 rpm in a clean, cool, lubricating, non-volatile liquid with an adequate flush rate. When used with the multiplier factors, the basic pressure rating can be adjusted to provide a conservative estimate of the dynamic pressure rating.

For process services outside this range for a more specific assessment of the dynamic pressure rating, contact John Crane for more information.

NOTES:

1. Basic pressure rating curve based on single-ply bellows.
2. Basic pressure rating curve is differential pressure applied to seal outside diameter.
3. Consult John Crane for applications outside these limits.

Multiplier Factors

	Selection Considerations	Multiplier Factors	
		Carbon vs. SiC	SiC vs. SiC T/C vs. SiC
Speed	Up to 3600 rpm Above 3600 rpm	x 1.00 x (3600/speed)	x 1.00 x (3600/speed)
Sealed Fluid Lubricity	Petrol/Gasoline, Kerosene, or Better Water and Aqueous Solutions (<176°F/80°C) Flashing Hydrocarbons* (see note 1)	x 1.00 x 0.75 x 0.60	x 1.00 x 0.75 (see note 2)
Sealed Fluid Temperature (see note 3)	Up to 175°F/80°C Up to 250°F/120°C Up to 400°F/205°C Up to 600°F/315°C Above 600°F/315°C	x 1.00 x 0.90 x 0.80 x 0.65 x 0.65	x 1.00 x 1.00 x 1.00 x 1.00 (see note 4)

* The ratio of sealed pressure to vapor pressure must be greater than 1.5, otherwise consult John Crane. If the specific gravity is less than 0.60, consult John Crane.

NOTES:

1. Specific gravity ≥ 0.6 and ratio of sealed pressure to vapor pressure > 1.5.
2. More details regarding the fluid and the operating conditions are required.
3. Temperature at the seal faces includes effects of flush, quench and cooling.
4. Contact John Crane Engineering for more information.

Example for Determining Dynamic Pressure Rating Limits

Seal: 3.5"/89mm diameter Type 1604
 Product: high viscosity gas oil (HVGO)
 Face material: carbon vs. silicon carbide
 Temperature: 620°F/325°C
 Shaft speed: 3600 rpm

Example for Determining Dynamic Pressure Rating:

The maximum pressure for a particular application is the lesser of the maximum pressure limit curve or the pressure calculated when the multiplier factors are applied to the specific seal face material curve.

Maximum pressure limit curve: 283 psi(g)/19.5 bar(g) max pressure

Carbon limit curve: 425 psi(g)/29.3 bar(g)

Calculated limit: 425 psi(g)/29.3 bar(g) x 1.00 x 1.00 x 0.65 = 276 psi(g)/19.0 bar(g)

At 3600 rpm with the service conditions noted, a 3.5"/89mm seal Type 1604 has a maximum operating pressure limit of 276 psi(g)/19.0 bar(g).

Materials of Construction

SEAL COMPONENTS	MATERIALS	
	Description	Standard
Mating Ring	Silicon Carbide Reaction Bonded	—
Primary Ring	Premium Grade Carbon	Tungsten Carbide Nickel Bound
Primary Ring Adapter	Alloy 42 (UNS K94100)	—
Adapter	Alloy 625 (UNS N06625)	—
Bellows	Alloy 718 (UNS N07718)	—
Adaptive Hardware	316 Stainless Steel	—
Static Seals	Flexible Graphite	—

Seal Welded Metal Bellows

Design Features

- Optimum 45° tilt angle
- Three-sweep radius
- Nesting ripple plate design
- static secondary seal
- Light spring loads

Benefits

- Uniform plate rigidity and stress distribution
- Enhanced fatigue strength
- Pressure-balanced by design
- Less heat
- Lower power consumption

Angular and Radial Movement

Excessive runout will have a detrimental effect on seal performance in the form of component wear or excessive leakage.

API 682 limits runout as follows:

- Centering of the seal is to be by a register fit. The register fit surface shall be concentric to the shaft and have a total indicated runout (FIM) of not more than 0.005"/125 micrometers
- Squareness of the seal chamber face to the shaft shall not exceed 0.0005" per inch of seal chamber bore (15 micrometers per cm)
- Runout of the sleeve outer diameter to the inner diameter shall be 0.001"/25 micrometers FIM
- Shaft-to-sleeve diametrical clearance shall be 0.001" to 0.003"/25 to 75 micrometers

Recommendations for Viscous Fluids

0 - 1,000 cSt: Standard seal

1,000 - 3,500 cSt: Hard face material

3,500 - 7,500 cSt: Drive lugs

7,500 - 10,500 cSt: Consult John Crane

NOTE: SSU (Saybolt Universal Seconds) approximately equals cSt (centistoke) x 4.6347

cP (centipoise) = cSt (centistoke) x specific gravity.

