

- A – Bellows Assembly
- B – Primary Ring
- C – Flexible Graphite Packing
- D – Primary Ring Adapter

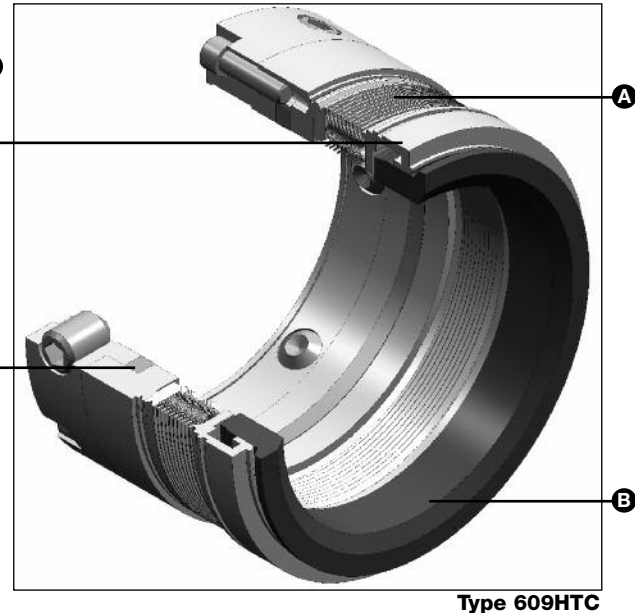

Sealor® Welded Metal Bellows

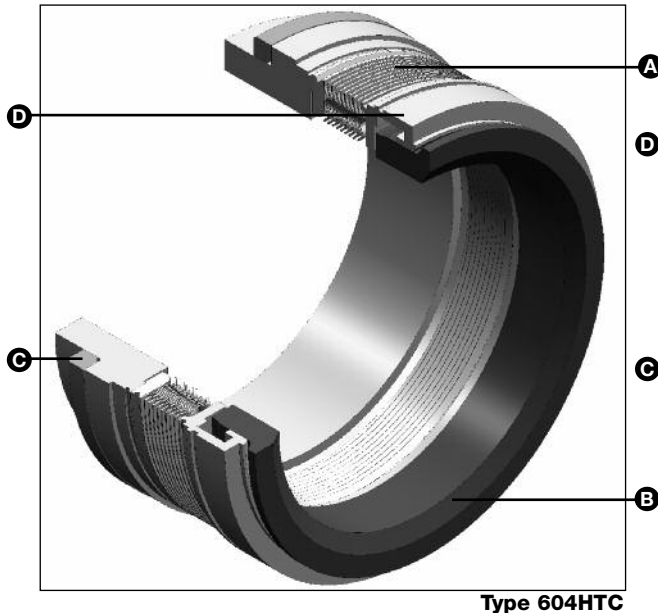

Product Description

The Type HTC* high-temperature corrosion resistant welded metal bellows seal is a unique advanced technology for reliably sealing fluids in harsh high-temperature corrosive environments. The Type HTC also provides superior face stability at elevated temperatures.

This all-Inconel® seal eliminates the need for plating and is ideally suited for applications that contain organic acids, broadly referred to as naphthenic acid, and sulfur compounds that attack most other alloys at high-temperature.

Specially designed pressure-compensating seal faces and a thermally compliant primary ring adapter provide exceptional seal face stability that adapts to a wide range of temperature excursions inherent in high-temperature applications.

Even if the application is not corrosive, the extra face stability provided by the seal can extend your MTBR in many other non-corrosive services.

The API 682/ISO 21049 qualified HTC seals are available in both stationary and rotating configurations, and single and dual seal arrangements.

Type 604HTC - high-temperature corrosion resistant stationary bellows assembly capable of handling high shaft speed applications and high shaft-to-seal chamber misalignment.

Type 609HTC - high-temperature bellows assembly intended for those demanding applications where a dependable, high-strength, rotating seal is preferred.

Performance Capabilities

- Temperature: -75°C to 425°C/-100°F to 800°F (with flexible graphite static packing)
- Pressure: dynamic - vacuum to 20 barg/300psig static - 31 barg/450 psig (see basic pressure ratings)
- Speed: Type 604HTC - up to 50 mps / 10,000 fpm
Type 609HTC - up to 25 mps / 5000 fpm

Design Features

- All-inconel metallurgy – meets NACE MR0175/MR0103
- ID and OD pressure capability – withstands reverse pressurization
- Thermally compliant primary ring adapter
- Pressure compensating primary ring
- Edge-welded metal bellows
- Advanced silicon carbide composite
- API 682/ISO 21049 qualification tested
- Available in single or dual cartridge arrangements
- Narrow radial cross-section fits most popular pump models without modification
- HTC is used as a component in many cartridge arrangements and configurations

Type 604HTC/609HTC

HIGH-TEMPERATURE CORROSION RESISTANT SEALS

Type 604HTC Typical Arrangement (Shaft Mounted Excluding Steam Guide)

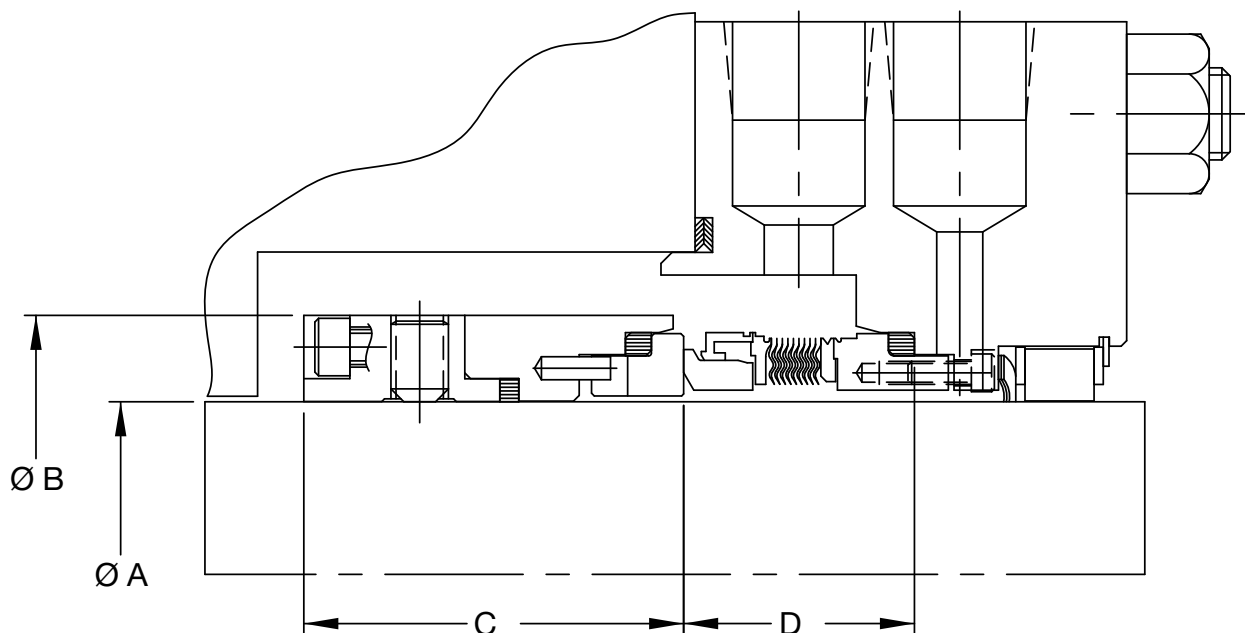

Typical 604HTC Dimensional Data (Shaft Mounted Excluding Steam Guide)

Seal Dash Number (size code)	inch				mm			
	A +0.000 -0.002	B Ref.	C Ref.	D Ref.	A +0.000 -0.050	B Ref.	C Ref.	D Ref.
-28	1.625	2.562	2.060	1.222	41.28	65.07	52.32	31.04
-30	1.750	2.687	2.060	1.254	44.45	68.25	52.32	31.85
-32	1.875	2.812	2.062	1.254	47.63	71.42	52.37	31.85
-34	2.000	2.937	2.060	1.285	50.80	74.60	52.32	32.64
-36	2.125	3.187	2.182	1.316	53.98	80.95	55.42	33.43
-38	2.250	3.312	2.218	1.348	57.15	84.12	56.34	34.24
-40	2.375	3.437	2.186	1.379	60.33	87.30	55.52	35.03
-42	2.500	3.562	2.184	1.410	63.50	90.47	55.47	35.81
-44	2.625	3.687	2.250	1.443	66.68	93.65	57.15	36.65
-46	2.750	3.937	2.250	1.608	69.85	100.00	57.15	40.84
-48	2.875	4.062	2.281	1.608	73.03	103.17	57.94	40.84
-50	3.000	4.187	2.250	1.608	76.20	106.35	57.15	40.84
-52	3.125	4.312	2.250	1.608	79.38	109.52	57.15	40.84
-54	3.250	4.437	2.219	1.608	82.55	112.70	56.36	40.84
-56	3.375	4.562	2.282	1.608	85.73	115.87	57.96	40.84
-58	3.500	4.687	2.373	1.650	88.90	119.05	60.27	41.91
-60	3.625	4.812	2.375	1.650	92.08	122.22	60.33	41.91
-62	3.750	4.937	2.375	1.650	95.25	125.40	60.33	41.91
-64	3.875	5.062	2.375	1.650	98.43	128.57	60.33	41.91
-68	4.125	5.312	2.188	1.650	104.78	134.92	55.58	41.91
-72	4.375	5.562	2.375	1.650	111.13	141.27	60.33	41.91
-76	4.625	5.812	2.360	1.650	117.48	147.62	59.94	41.91
-80	4.875	6.187	2.375	1.650	123.83	157.15	60.33	41.91
-84	5.125	6.437	2.375	1.806	130.18	163.50	60.33	45.87
-88	5.375	6.687	2.375	1.806	136.53	169.85	60.33	45.87
-92	5.625	6.937	2.375	1.806	142.88	176.20	60.33	45.87
-104	6.375	7.687	2.375	1.806	161.93	195.25	60.33	45.87
-112	6.875	8.187	2.375	1.806	174.63	207.95	60.33	45.87

Note: "A" is the maximum shaft or sleeve diameter in arrangements excluding a steam guide sleeve.

Type 604HTC/609HTC

HIGH-TEMPERATURE CORROSION RESISTANT SEALS

Technical Specification

Type 604HTC Typical Arrangement (Shaft Mounted with Steam Guide)

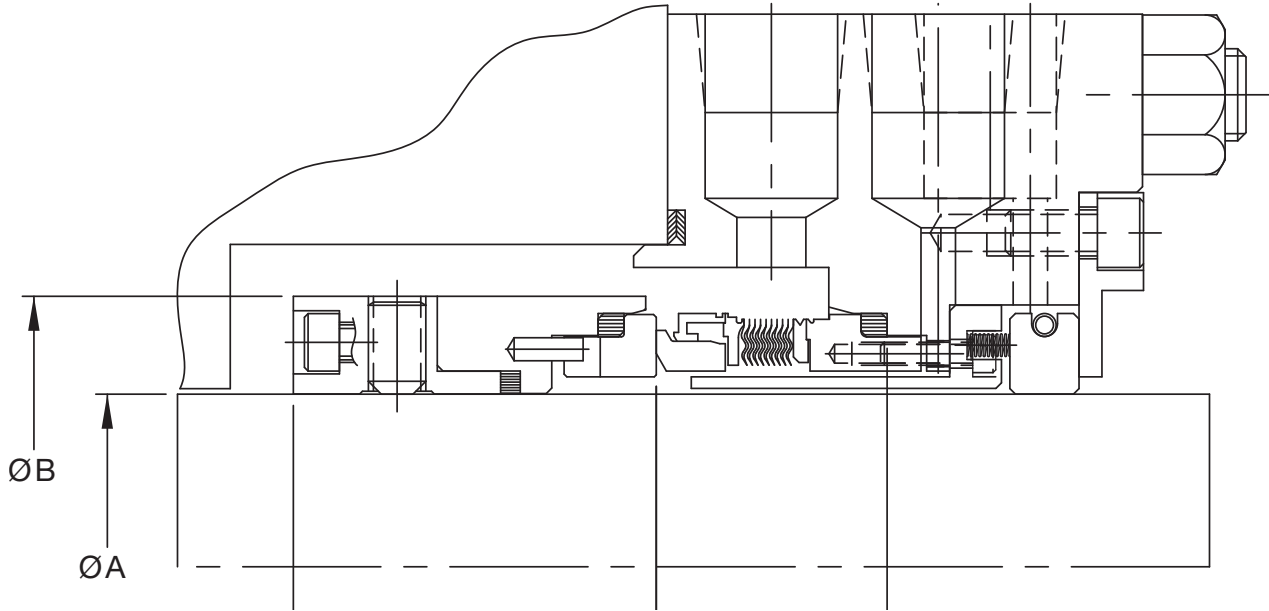

Type 604HTC Dimensional Data (Shaft Mounted with Steam Guide)

Seal Dash Number (size code)	Inch				mm			
	A +0.000 -0.002	B Ref.	C Ref.	D Ref.	A +0.000 -0.050	B Ref.	C Ref.	D Ref.
-28	1.500	2.562	2.057	1.222	38.10	65.07	52.25	31.04
-30	1.625	2.687	2.065	1.253	41.28	68.25	52.45	31.83
-32	1.750	2.812	2.065	1.253	44.45	71.42	52.45	31.83
-34	1.875	2.937	1.970	1.285	47.63	74.60	50.04	32.64
-36	2.000	3.187	2.189	1.317	50.80	80.95	55.60	33.45
-38	2.125	3.312	2.230	1.348	53.98	84.12	56.64	34.24
-40	2.250	3.437	2.189	1.379	57.15	87.30	55.60	35.03
-42	2.375	3.562	2.189	1.411	60.33	90.47	55.60	35.84
-44	2.500	3.687	2.252	1.443	63.50	93.65	57.20	36.65
-46	2.625	3.937	2.345	1.608	66.68	100.00	59.56	40.84
-48	2.750	4.063	2.282	1.608	69.85	103.20	57.96	40.84
-50	2.875	4.187	2.283	1.608	73.03	106.35	57.99	40.84
-52	3.000	4.312	2.283	1.608	76.20	109.52	57.99	40.84
-54	3.125	4.437	2.282	1.608	79.38	112.70	57.96	40.84
-56	3.250	4.563	2.283	1.608	82.55	115.90	57.99	40.84
-58	3.375	4.687	2.377	1.650	85.73	119.05	60.38	41.91
-60	3.500	4.812	2.377	1.650	88.90	122.22	60.38	41.91
-62	3.625	4.937	2.377	1.650	92.08	125.40	60.38	41.91
-64	3.750	5.062	2.377	1.650	95.25	128.57	60.38	41.91
-68	4.000	5.312	2.377	1.650	101.60	134.92	60.38	41.91
-72	4.250	5.563	2.377	1.650	107.95	141.30	60.38	41.91
-76	4.500	5.812	2.377	1.650	114.30	147.62	60.38	41.91
-80	4.750	6.188	2.377	1.650	120.65	157.18	60.38	41.91
-84	5.000	6.437	2.377	1.806	127.00	163.50	60.38	45.87
-88	5.250	6.687	2.377	1.806	133.35	169.85	60.38	45.87
-92	5.500	6.937	2.377	1.806	139.70	176.20	60.38	45.87
-104	6.250	7.687	2.377	1.806	158.75	195.25	60.38	45.87
-112	6.750	8.187	2.377	1.806	171.45	207.95	60.38	45.87

Note: "A" is the maximum shaft or sleeve diameter in arrangements utilizing a steam guide sleeve.

Type 604HTC/609HTC

HIGH-TEMPERATURE CORROSION RESISTANT SEALS

Technical Specification

Type 609HTC Dimensional Data (Standard Drive Collar)

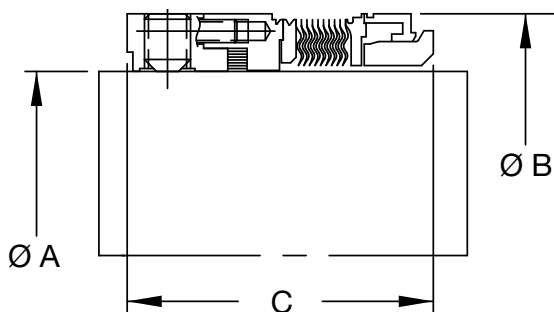

Note: Consult John Crane Engineering to select the appropriate drive collar variation for your seal arrangement.

Seal Dash Number (size code)	inch			mm		
	A +0.000 -0.002	B Ref.	C Ref.	A +0.000 -0.050	B Ref.	C Ref.
-40	2.500	3.265	1.750	63.50	82.93	44.45
-42	2.625	3.390	1.781	66.68	86.11	45.24
-44	2.750	3.516	1.781	69.85	89.31	45.24
-46	2.875	3.705	1.875	73.03	94.11	47.63
-48	3.000	3.831	1.875	76.20	97.31	47.63
-50	3.125	4.019	1.875	79.38	102.08	47.63
-52	3.250	4.145	1.875	82.55	105.28	47.63
-54	3.375	4.271	1.875	85.73	108.48	47.63
-56	3.500	4.396	1.875	88.90	111.66	47.63
-58	3.625	4.522	1.875	92.08	114.86	47.63
-60	3.750	4.648	1.875	95.25	118.06	47.63
-62	3.875	4.774	1.875	98.43	121.26	47.63
-64	4.000	4.899	1.875	101.60	124.43	47.63

Type 609HTC Dimensional Data (One Step Drive Collar)

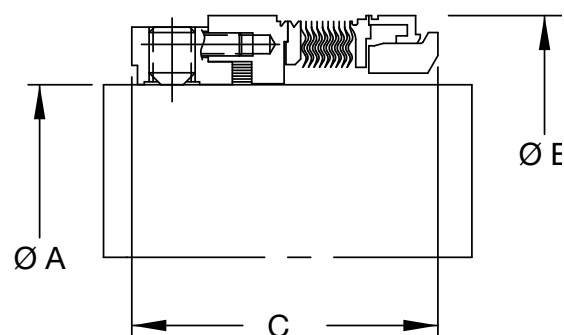

Note: Consult John Crane Engineering to select the appropriate drive collar variation for your seal arrangement.

Seal Dash Number (size code)	inch			mm		
	A +0.000 -0.002	B Ref.	C Ref.	A +0.000 -0.050	B Ref.	C Ref.
-28	1.625	2.385	1.625	41.28	60.58	41.27
-30	1.750	2.511	1.656	44.45	63.78	42.06
-32	1.875	2.637	1.656	47.63	66.98	42.06
-34	2.000	2.762	1.656	50.80	70.15	42.06
-36	2.125	2.887	1.656	53.98	73.33	42.06
-38	2.250	3.013	1.750	57.15	76.53	44.45
-40	2.375	3.265	1.750	60.33	82.93	44.45
-42	2.500	3.390	1.781	63.50	86.11	45.23
-44	2.625	3.516	1.781	66.68	89.31	45.23
-46	2.750	3.705	1.875	69.85	94.11	47.62
-48	2.875	3.831	1.875	73.03	97.31	47.62
-50	3.000	4.019	1.875	76.20	102.08	47.62
-52	3.125	4.145	1.875	79.38	105.28	47.62
-54	3.250	4.271	1.875	82.55	108.48	47.62
-56	3.375	4.396	1.875	85.73	111.66	47.62
-58	3.500	4.522	1.875	88.90	114.86	47.62
-60	3.625	4.648	1.875	92.08	118.06	47.62
-62	3.750	4.774	1.875	95.25	121.26	47.62
-64	3.875	4.899	1.875	98.43	124.43	47.62
-68	4.000	5.214	1.875	101.60	132.44	47.63
-72	4.250	5.465	1.875	107.95	138.81	47.63
-76	4.500	5.717	1.875	114.30	145.21	47.63
-80	4.750	5.969	1.875	120.65	151.61	47.63
-84	5.000	6.243	2.281	127.00	158.57	57.94
-88	5.250	6.495	2.281	133.35	164.97	57.94
-92	5.500	6.747	2.281	139.70	171.37	57.94
-104	6.000	7.501	2.281	152.40	190.53	57.94
-112	6.500	8.005	2.281	165.10	203.33	57.94

Type 609HTC Dimensional Data (Two Step Drive Collar)

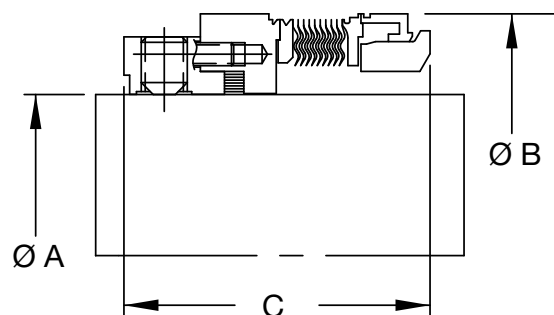

Note: Consult John Crane Engineering to select the appropriate drive collar variation for your seal arrangement.

Seal Dash Number (size code)	inch			mm		
	A +0.000 -0.002	B Ref.	C Ref.	A +0.000 -0.050	B Ref.	C Ref.
-28	1.500	2.385	1.625	38.10	60.58	41.27
-30	1.625	2.511	1.625	41.28	63.78	41.27
-32	1.750	2.637	1.656	44.45	66.98	42.06
-34	1.875	2.762	1.656	47.63	70.15	42.06
-36	2.000	2.887	1.688	50.80	73.33	42.87
-38	2.125	3.013	1.688	53.98	76.53	42.87
-40	2.250	3.265	1.781	57.15	82.93	45.23
-42	2.375	3.390	1.781	60.33	86.11	45.23
-44	2.500	3.516	1.781	63.50	89.31	45.23
-46	2.625	3.705	1.875	66.68	94.11	47.62
-48	2.750	3.831	1.875	69.85	97.31	47.62
-50	2.875	4.019	1.875	73.03	102.08	47.62
-52	3.000	4.145	1.875	76.20	105.28	47.62
-54	3.125	4.271	1.875	79.38	108.48	47.62
-56	3.250	4.396	1.875	82.55	111.66	47.62
-58	3.375	4.522	1.875	85.73	114.86	47.62
-60	3.500	4.648	1.875	88.90	118.06	47.62
-62	3.625	4.774	1.875	92.08	121.26	47.62
-64	3.750	4.899	1.875	95.25	124.43	47.62

Type 604HTC/609HTC

HIGH-TEMPERATURE CORROSION RESISTANT SEALS

Technical Specification

Typical Type 604HTC Single Arrangement (API 682/ISO 21049 Type 1604HTC)

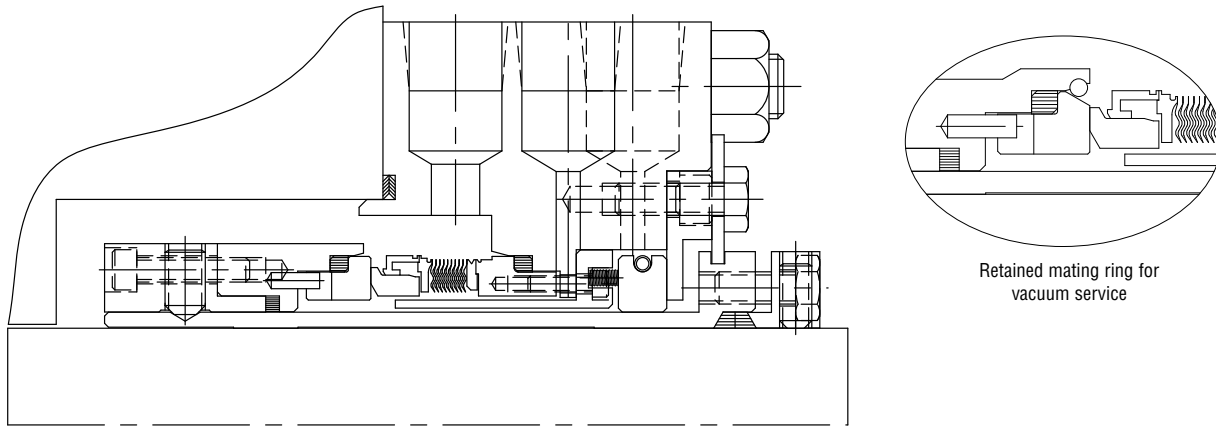

A single stationary Type 604HTC seal that contains a steam guide (steam deflector or anti-coking baffle) which directs steam to the area where coke would tend to form and routes the steam to carry material away from the seal and seal faces.

Typical Type 609HTC/ECS Arrangement

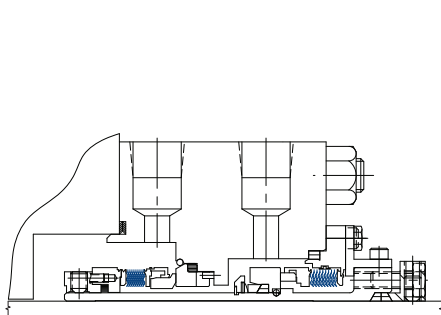

A dual high-temperature emission containment seal (ECS) with inner rotating, 609HTC seal. The ECS, along with a steam quench, provides an additional level of safety/back-up in high-temperature applications.

Typical Type 604HTC/ECS Arrangement

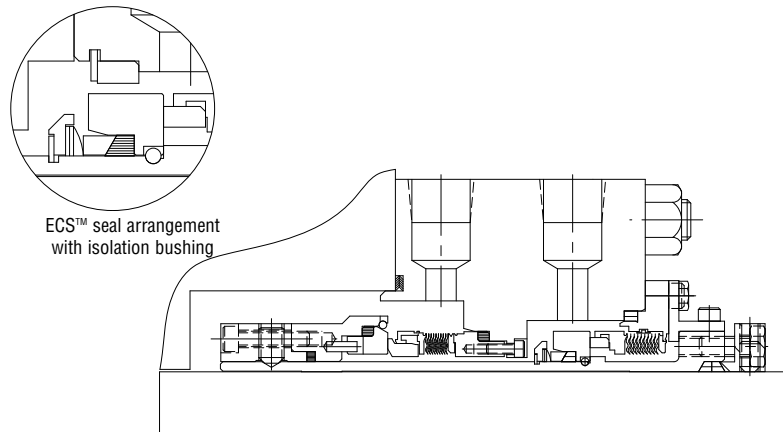

A dual high-temperature emission containment seal (ECS) with inner stationary, 604HTC seal. The ECS, along with a steam quench, provides an additional level of safety/back-up in high-temperature applications.

Typical Type 2609HTC/3609HTC Tandem Arrangement

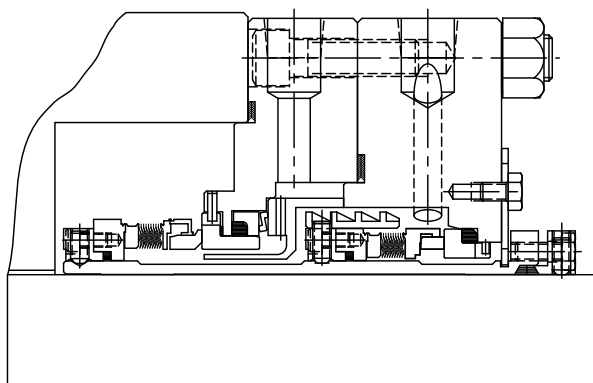

A dual seal in which one mating ring is mounted between the two flexible elements (bellows) and one flexible element is mounted between the two mating seal rings. Arrangement has a Type 609HTC inner seal with standard Type 609 or 609HTC outer seal.

Typical Type 604HTC Dual Face-To-Face Arrangement

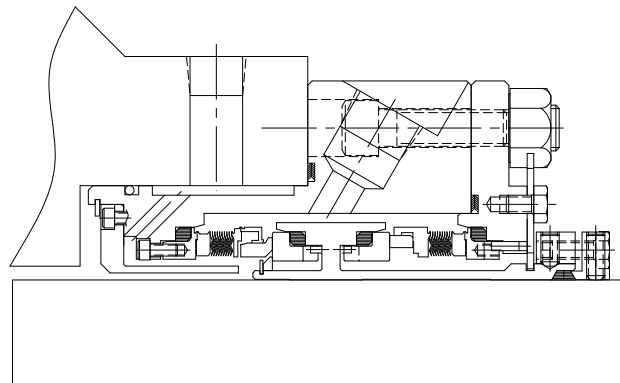

A dual seal in which both of the mating seal rings are mounted between the flexible elements (bellows). Arrangement has a Type 604HTC inner seal with standard Type 604 or 604HTC outer seal.

Type 604HTC/609HTC

HIGH-TEMPERATURE CORROSION RESISTANT SEALS

Basic Pressure Rating

Type 604HTC/609HTC OD Pressure Rating

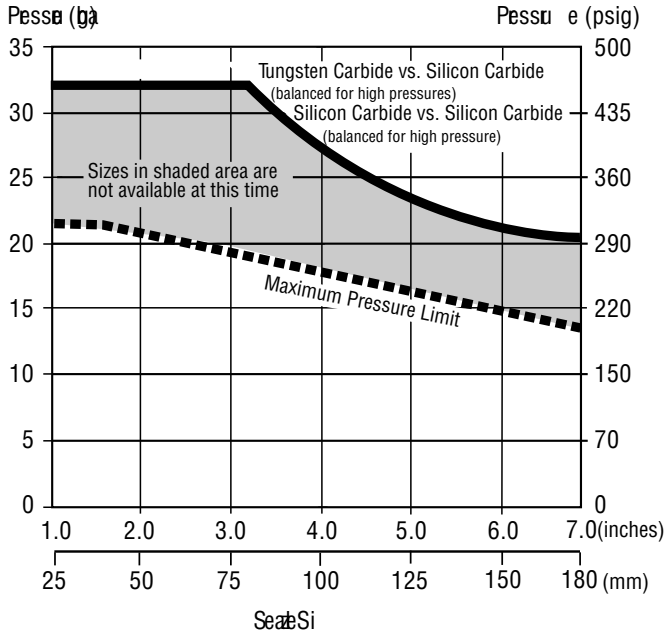

Type 604HTC/609HTC ID Pressure Rating

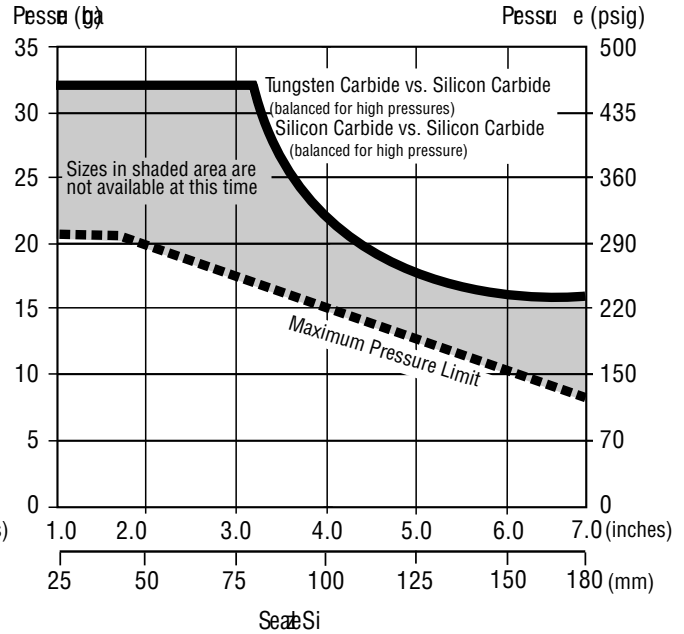

Notes:

1. Basic pressure rating curve based on single-ply bellows.
2. Basic pressure rating curve is differential pressure applied to seal outside diameter.

The basic pressure rating is for a standard seal, as shown in the typical arrangement, when installed according to the criteria given in this data sheet and generally accepted industrial practices.

The basic pressure rating assumes stable operation at 3600 rpm in a clean, lubricating, non-volatile liquid with an adequate flush rate. When used with the multiplier factors, the basic pressure rating can be adjusted to provide a conservative estimate of the dynamic pressure rating.

Contact John Crane for process services outside this range or a more specific assessment of the dynamic pressure rating.

Notes:

1. Basic pressure rating curve based on single-ply bellows.
2. For applications above 600°F(315°C) and 200psig(13.8 barg), consult John Crane.

Multiplier Factors

	Selection Consideration	Multiplier Factor
Speed	Up to 3600 rpm Above 3600 rpm	x 1.00 x (3600/speed)
Sealed Fluid Lubricity	Petroleum/Gasoline, Kerosene, Lube Oil, etc. Water and Aqueous Solutions (< 80°C/176°F) Light Hydrocarbons (see Note 1)	x 1.00 x 0.75 (see Note 2)
Sealed Fluid Temperature (see Note 3)	Up to 425°C/800°F	x 1.00

Notes:

1. Specific gravity ≥ 0.6 and ratio of sealed pressure to vapor pressure > 1.5 .
2. More details regarding the fluid and the operating conditions are required.
3. Temperature at the seal faces includes effects of flush, quench, and cooling. Temperatures must not exceed limits shown in max. temperature limits section.

Example for determining OD pressure rating limits:

Seal: Type 604HTC
 Size: 3.00"/76mm
 Product: high viscosity gas oil
 Face material: sealide-C vs. silicon carbide
 Operating temperature: 325°C/620°F
 Operating speed: 3600 rpm

Example for determining OD dynamic pressure rating:

The maximum pressure for a particular application is the lesser of the maximum pressure limit curve or the pressure calculated when the multiplier factors are applied to the specific seal face material curve.

Maximum pressure limit curve:
 20 barg/290 psig max. pressure

Hard faces limit curve: 32 barg/460 psig

Calculated limit: 32 barg/460 psig x 1.00 x 1.00 x 1.00 = 32 barg/460 psig

At 3600 rpm with the service conditions noted, a 3.00"/ 76mm (seal size) Type 604HTC has a maximum operating pressure limit of 20 barg/290 psig.

Multiplier Factors (continued)

Example for determining ID pressure rating limits:

Seal: Type 609HTC

Size: 2.00"/50mm

Product: residuum

Face material: Sealide-C vs. silicon carbide

Operating temperature: 315°C/600°F

Operating speed: 3600 rpm

Example for determining ID dynamic pressure rating:

The maximum ID pressure for a particular application is the lesser of the maximum pressure limit curve or the pressure calculated when the multiplier factors are applied to the specific seal face material curve.

Maximum pressure limit curve: 16.5 barg/240 psig max. ID pressure

Hard faces limit curve: 20 barg/300 psig

Calculated limit: 20 barg/300 psig x 1.00 x 1.00 x 1.00 = 20 barg/300 psig

At 3600 rpm with the service conditions noted, an 2.0"/50mm (Seal Size) Type 609HTC has a maximum operating pressure limit of 16.5 barg/240 psig max ID pressure.

Materials of Construction

SEAL COMPONENTS	MATERIALS	
	Standard	Options
Bellows	Alloy 718 (UNS N07718)	—
Primary Ring	Sealide-C (Sintered)	Tungsten Carbide*
Static Seals	Flexible Graphite	—
Primary Ring Adapter	Alloy 718 (UNS N07718)	—
Adapter	Alloy 718 (UNS N07718)	—

*Tungsten Carbide recommended for process temperatures less than -40°C/-40°F.

Welded Metal Bellows

Bellows design features:

- Optimum 45° tilt angle
- Three-sweep radius
- Nesting ripple plate design
- Static secondary seal
- Light spring loads

Bellows benefits:

- Uniform plate rigidity and stress distribution
- Enhanced fatigue strength
- Pressure-balanced by design
- Less heat generated
- Lower power consumption

Sealide-C Advanced Silicon Carbide Composite Primary Ring

Sealide-C is a state-of-the-art sintered silicon carbide with low friction and the inherent lubricity of free graphite. This silicon carbide is a tough, hard, heat resistant, long wearing, inert seal face material. When compared with other face materials, Sealide-C provides improved corrosion resistance, improved thermal shock resistance, and lower running face temperatures.

Technology

The HTC seal provides an effective solution in sealing corrosive fluids at elevated temperatures by utilizing a complete all-Inconel metallurgy and unique face seal technology that provides exceptional stability across a wide range of pressure/temperature conditions.

An effective means of ensuring seal reliability is by controlling seal face distortion, which directly affects the operating conditions at the sealing surface. Pressure compensating seal faces and thermally compliant components ensure exceptional seal face flatness stability that resists any compromising effects from temperature and pressure. Such exceptional face stability can result in reduced leakage and longer seal life.

In dual seal arrangements, the HTC is capable of handling reverse pressurization. In a dual unpressurized bellows arrangement, the primary seal is designed to contain a buffer reverse pressure. In a pressurized dual seal arrangement the primary seal normally operates with reverse barrier pressure and is designed to contain the process fluid in the event of loss of barrier pressure.

The HTC has proven to be a superior design for high temperature corrosive applications up to 800°F/425°C.

Typical Applications

- Hydrocarbons
- Aromatic fractionation products (benzene, toluene, solvents, etc.)
- Crude oil fractionation products (fuel oil, lubricating oil, gasoline, etc.)
- Chemicals, caustics, some acids, aqueous solutions, lubricating liquids
- Heat transfer fluids
- Cryogenic

Inconel is a registered to Inco Alloys International Inc.

