

Submersible Pumps

## ENDURO Lite SERIES



## TECHNICAL MANUAL



# ENDURO 50 Lite – ENDURO 100 Lite – ENDURO 150 Lite

Submersible Pumps for Unwatering



Mas Grup

## General Specifications

### Description

ENDURO 50, 100, 150 Lite series of submersible pumps is monophase, easy to assemble with float switch and they work automatically.

They are manufactured in keeping with 50 and 60 Hz.

### Areas of Usage

These pumps having open impeller being made of Noryl material can be used in pools and waterfalls and backwater evacuations in buildings. Their maximum head is 14 m and they can discharge max 3 mm particle.

### Pump Material Specifications

Pump Casing	: PPH
Impeller	: Noryl
Shaft	: AISI 304 INOX
Fluid Temperature	: 0 – 30 °C
Protection Class	: IP 68
Isolation	: Cl.F
Cable Length	: 10 m
Mechanical Seal	: Silicium/Silicium

*Thermal protection is available for overloads in monophase types.*

Type	Control Panel	Open Impeller	Close Impeller	Grinder Blade	Stainless Steel (AISI 304 INOX)	Cast Iron (GG25)	Noryl Impeller
ENDURO 50 Lite		✓					✓
ENDURO 100 Lite		✓					✓
ENDURO 150 Lite		✓					✓

### Pump Technical Specifications

Type	MOTOR							PUMP									
	kW	V	Hz	A	Rpm	Capacitor uf	Vc	Inlet Outlet	Ø mm	H mm	Kg	m³/h	1	3	5	7	10
ENDURO 50 Lite	0.37	220	50	1.7	2900	10	450	1"	147	248	4.5	mwc	8	6	4	-	-
ENDURO 100 Lite	0.65	220	50	4.3	2900	20	450	1 ¼"	180	326	11		10.5	10	9	7	-
ENDURO 150 Lite	1	220	50	4.4	2900	25	450	1 ¼"	180	326	12		13.5	12.5	11	9	4

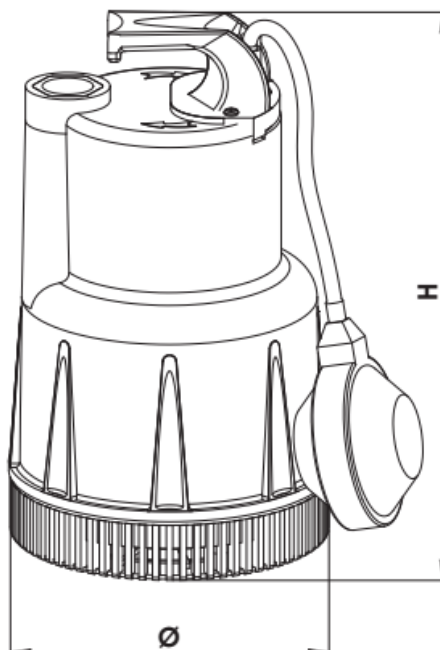

# ENDURO 150S Lite

Submersible Pumps for Mildly Dirty Water

## General Specifications



Mas Grup

### Description

ENDURO 150S Lite series of submersible pumps is monophase, easy to assemble with float switch and stainless casing and they work automatically.

They are manufactured in keeping with 50 and 60 Hz.

### Areas of Usage

These pumps having close impeller being made of AISI 304 INOX stainless steel material can be used in decorative pools, waterfalls and backwater evacuations in buildings. Their maximum head is 20 m and they can discharge max 6 mm particle.

### Pump Material Specifications

Pump Casing	: INOX
Impeller	: AISI 304 INOX
Shaft	: AISI 304 INOX
Fluid Temperature	: 0 – 30 °C
Protection Class	: IP 68
Isolation	: Cl.F
Cable Length	: 10 m
Mechanical Seal	: Silicium/Silicium

*Thermal protection is available for overloads in monophase types.*

Type	Control Panel	Open Impeller	Close Impeller	Grinder Blade	Stainless Steel (AISI 304 INOX)	Cast Iron (GG25)	Noryl Impeller
ENDURO 150S Lite	✓		✓		✓		

### Pump Technical Specifications

Type	MOTOR								PUMP									
	kW	HP	V	Hz	A	Rpm	Capacitor uf	Vc	Inlet Outlet	W mm	L mm	H mm	Kg	m³/h	3	8	12	16
ENDURO 150S Lite	1.1	1.5	220	50	6.2	2900	25	450	1 ½"	185	260	350	19.7	mwc	16.5	14	11	7.5

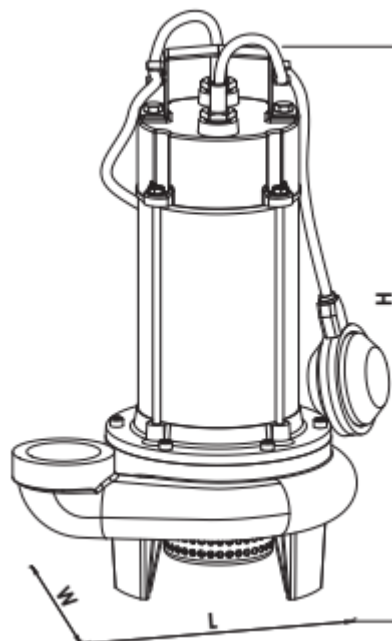

# ENDURO 150F Lite

Submersible Pumps for Cesspit

## General Specifications



Mas Grup

### Description

ENDURO 150F Lite series of submersible pumps using in dirty water supply is monophase, easy to assemble with float switch and they work automatically.

They are manufactured in keeping with 50 and 60 Hz.

### Areas of Usage

These pumps having open impeller being made of AISI 304 INOX stainless steel material can be used in discharging of sewage liquids containing max 20 mm particle and industrial and domestic wastewater and rain water. Also they can be used in little pools and waterfalls. Their maximum head is 12 m and they can discharge max 20 mm particle.

### Pump Material Specifications

Pump Casing	: PPH
Impeller	: AISI 304 INOX
Shaft	: AISI 304 INOX
Fluid Temperature	: 0 – 30 °C
Protection Class	: IP 68
Isolation	: Cl.F
Cable Length	: 10 m
Mechanical Seal	: Silicium/Silicium

*Thermal protection is available for overloads in monophase types.*

Type	Control Panel	Open Impeller	Close Impeller	Grinder Blade	Stainless Steel (AISI 304 INOX)	Cast Iron (GG25)	Noryl Impeller
ENDURO 150F Lite		✓			✓		

### Pump Technical Specifications

Type	MOTOR							PUMP											
	kW	HP	V	Hz	A	Rpm	Capacitor uf	Vc	Inlet Outlet	W mm	L mm	H mm	Kg	m³/h	3	6	9	11	16
ENDURO 150F Lite	1.1	1.5	220	50	5.2	2900	25	450	2"	185	195	400	13	mwc	9	8	7	6	3

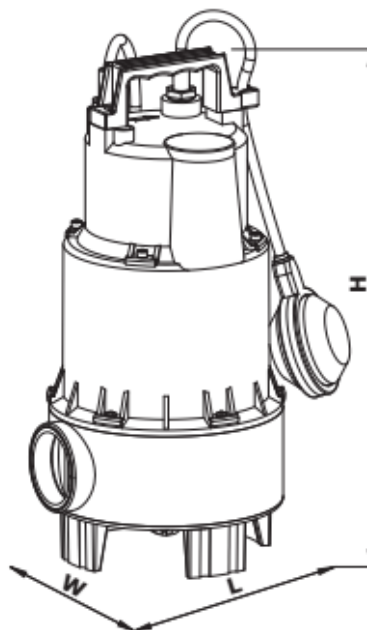

# ENDURO 200S Lite

Submersible Pumps for Mildly Dirty Water

## General Specifications



Mas Grup

### Description

ENDURO 200S Lite series of submersible pumps is monophase, easy to assemble with float switch and stainless casing and they work automatically.

They are manufactured in keeping with 50 and 60 Hz.

### Areas of Usage

These pumps having open impeller being made of cast iron material can be used in decorative pools, waterfalls and backwater evacuations in buildings. Their maximum head is 20 m and they can discharge max 6 mm particle.

### Pump Material Specifications

Pump Casing	: AISI 304 INOX
Impeller	: GG25 Cast Iron
Shaft	: AISI 304 INOX
Fluid Temperature	: 0 – 30 °C
Protection Class	: IP 68
Isolation	: Cl.F
Cable Length	: 10 m
Mechanical Seal	: Silicium/Silicium

*Thermal protection is available for overloads in monophase types.*

Type	Control Panel	Open Impeller	Close Impeller	Grinder Blade	Stainless Steel (AISI 304 INOX)	Cast Iron (GG25)	Noryl Impeller
ENDURO 200S Lite	✓	✓				✓	

### Pump Technical Specifications

Type	MOTOR								PUMP										
	kW	HP	V	Hz	A	Rpm	Capacitor uf	Vc	Inlet Outlet	W mm	L mm	H mm	Kg	m³/h	3	8	12	16	20
ENDURO 200S Lite	1.35	1.8	220	50	6,5	2900	30	450	2"	200	280	430	21,5	mwc	18	16	13	10	6

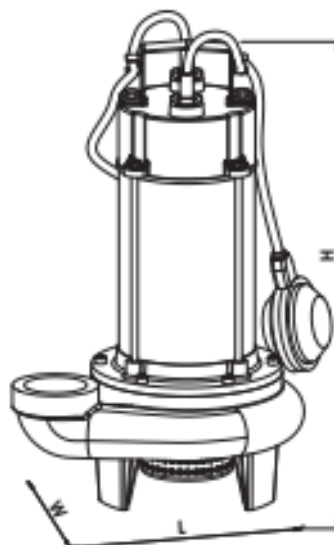

# ENDURO Lite Series

Submersible Pumps

## Performance Curves



Mas Grup

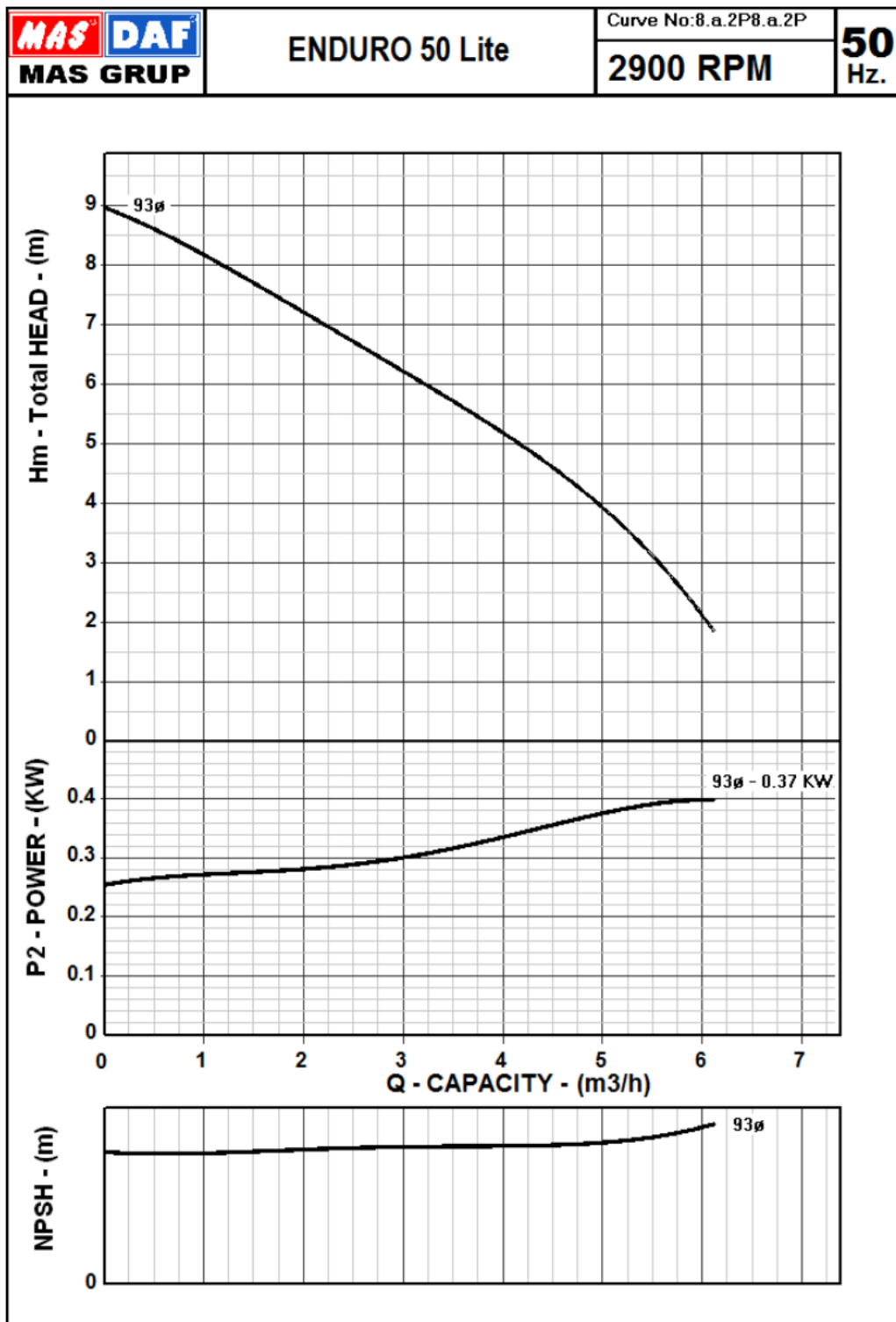

# ENDURO Lite Series

Submersible Pumps

## Performance Curves



Mas Grup

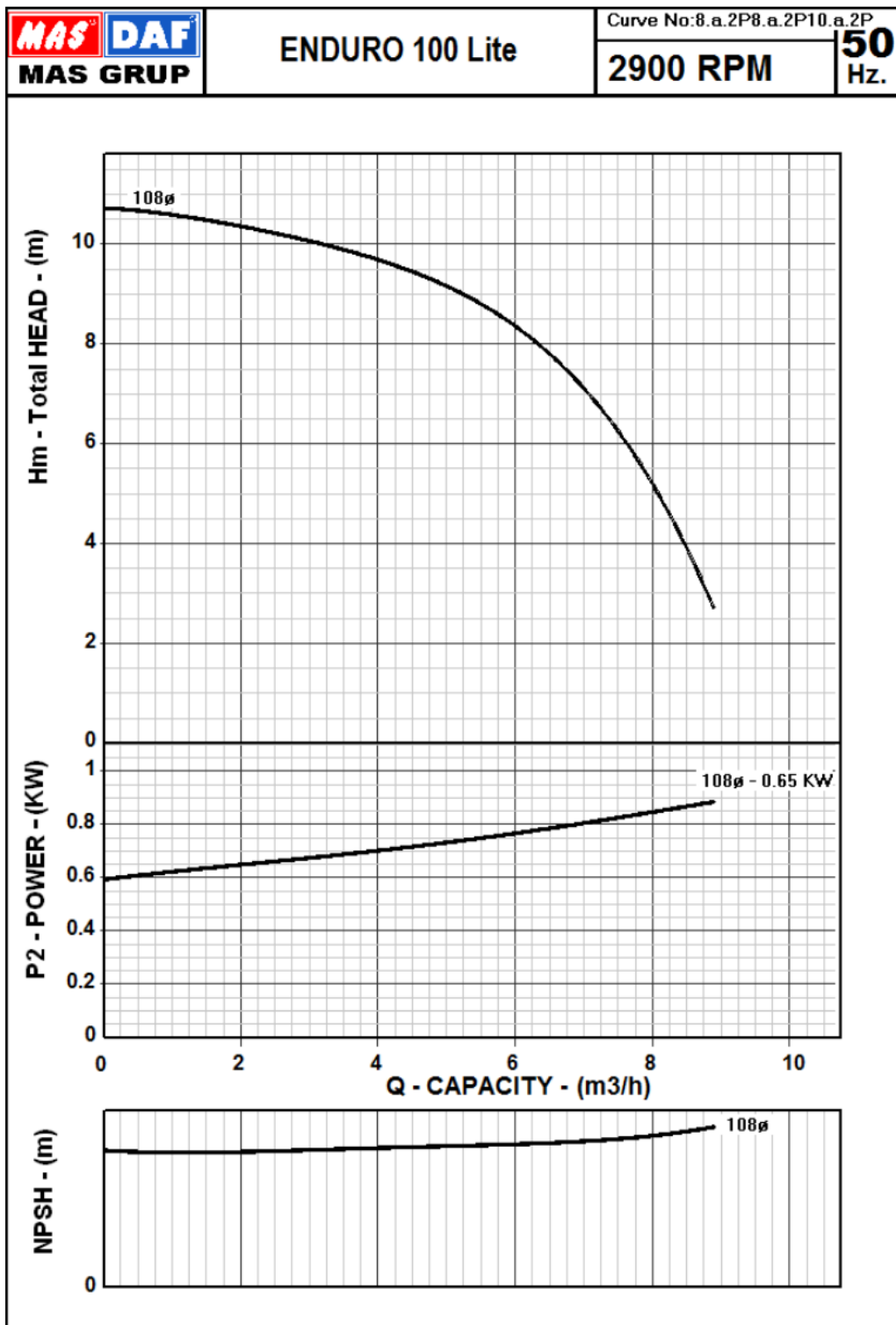

# ENDURO Lite Series

Submersible Pumps

## Performance Curves



Mas Grup

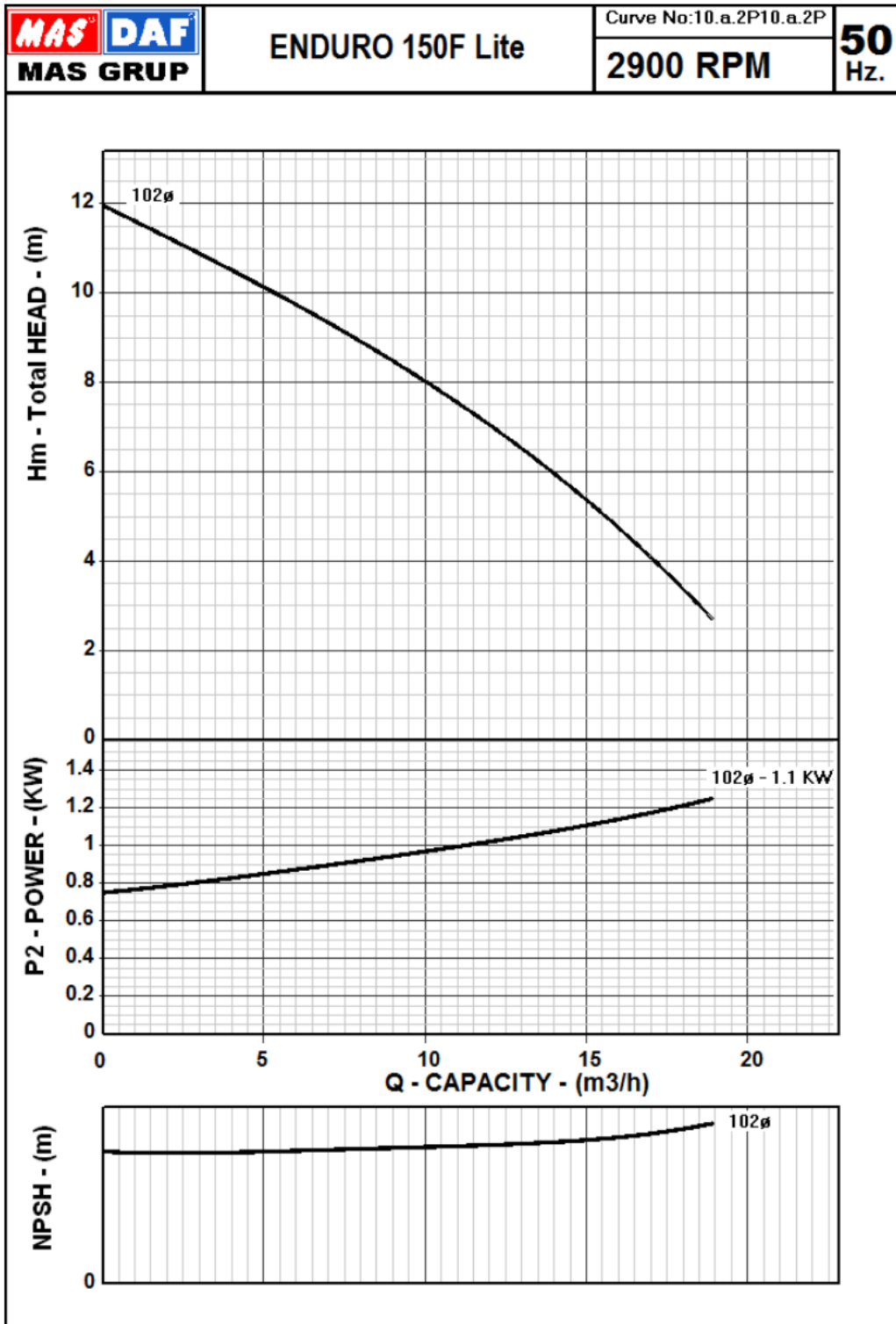



# ENDURO Lite Series

Submersible Pumps

## Performance Curves



Mas Grup

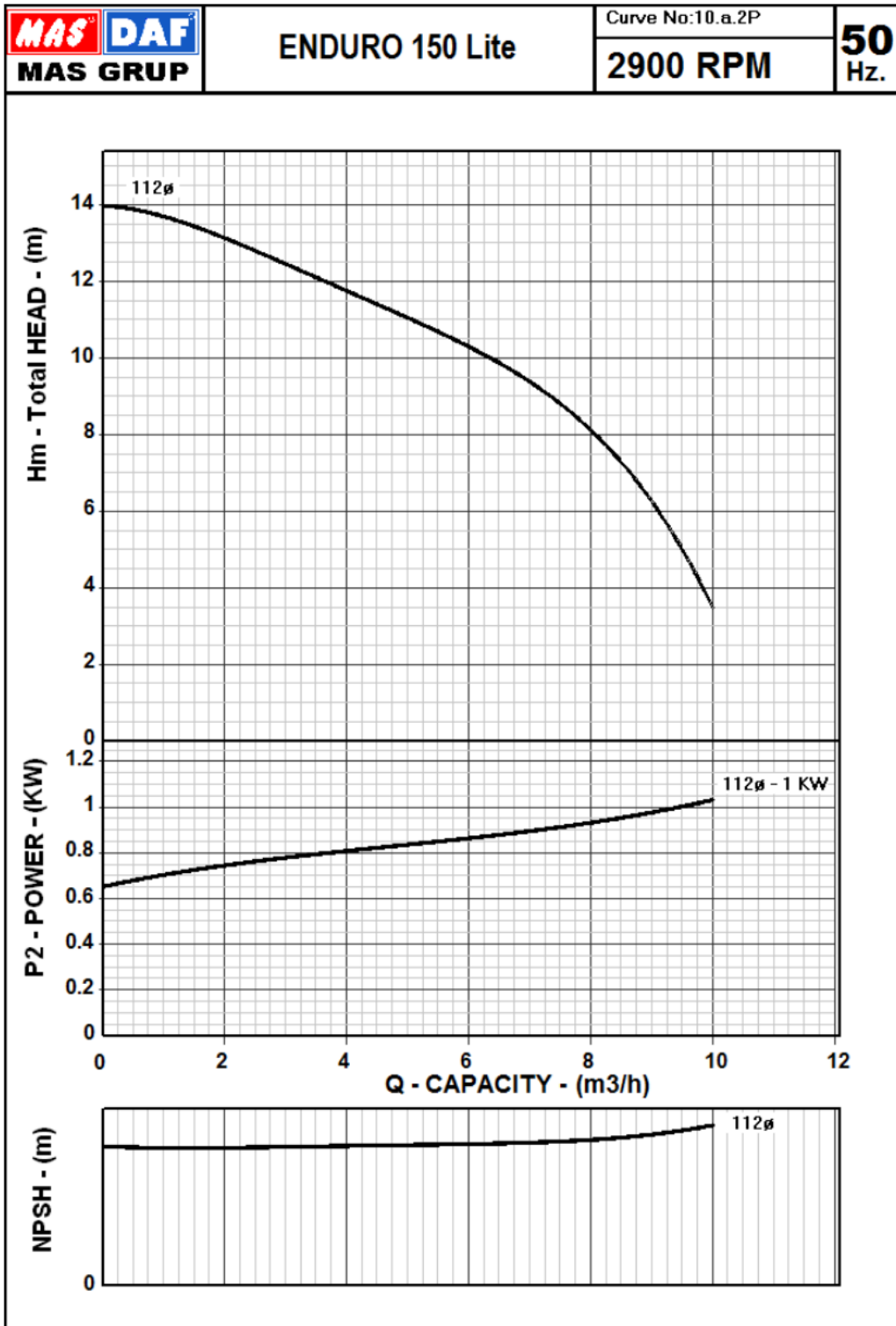

# ENDURO Lite Series

Submersible Pumps

## Performance Curves



Mas Grup

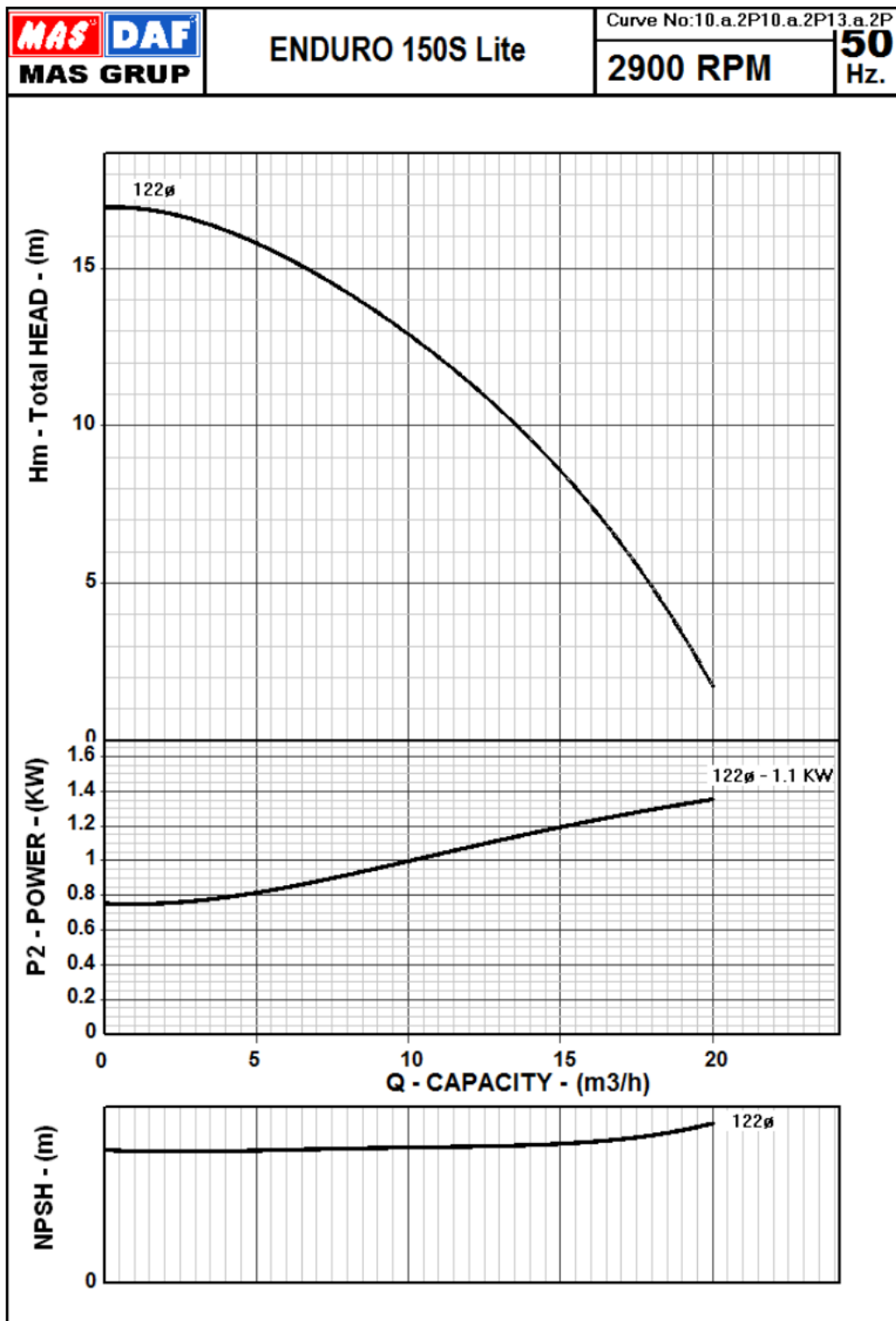

# ENDURO Lite Series

Submersible Pumps

## Performance Curves



Mas Grup

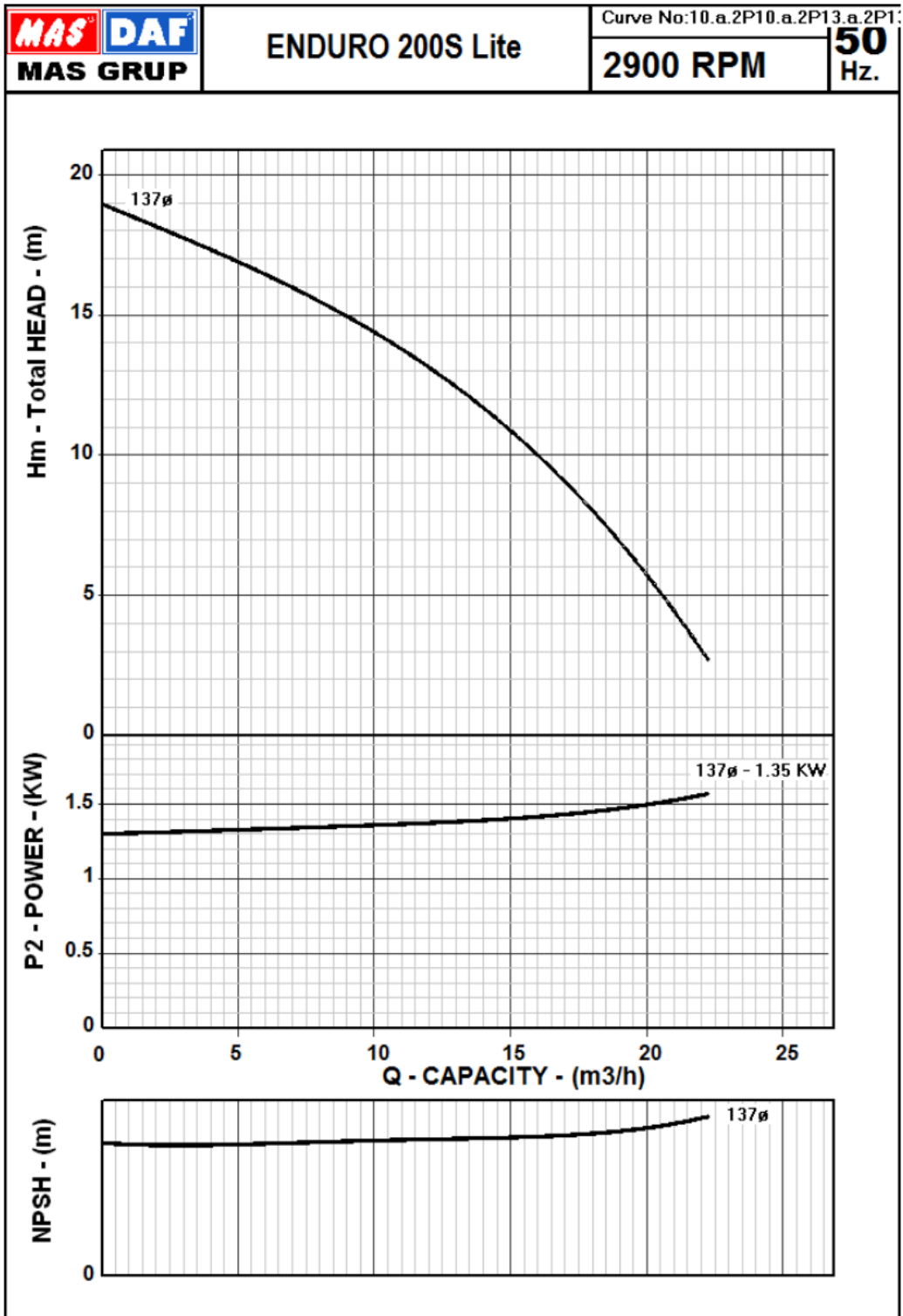



## **Mas Grup**

### **Head Office / Service Center:**

AydınlıMah. Birlik OSB. 1.No'lu Cadde No:17 Tuzla - İSTANBUL / TURKEY  
Tel: +90 (216) 456 47 00 pbx Fax: +90 (216) 455 14 24

### **Ankara Regional Directorate:**

Aşağı Öveçler Mah. 1329 Sok. No:6/9 Öveçler ANKARA / TURKEY  
Tel: +90 (312) 472 81 60-67 Fax: +90 (312) 472 82 51

### **Factory:**

1. Organize Sanayi Bölgesi Parsel 249/5 Beyköy - DÜZCE / TURKEY  
Tel: +90 (380) 553 73 88 Fax: +90 (380) 553 71 29